

Serie **13**

FN-1, U, FI

	SFT	FRD	SKL	FRL
13010	3	1	4	30
13015	3	1,5	6	30
13020B	3	2	8	30
13030	3	3	10	30
13060A	6	6	30	70



FRÄSEN PASSAR TILL
HÄRD PLAST, TRÄ

Serie **15**

FN-4, U

	SFT	FRD	SKL	FRL
15030	3	1	10	40
15060	6	6	16	60
15080	8	8	23	60



FRÄSEN PASSAR TILL
STÅL, ROSTFRITT STÅL

Serie **45**

FN-4, U

	SFT	FRD	SKL	FRL
45190	6	20	-	-



FRÄSEN PASSAR TILL
PLANFRÄSNING

Serie **33**

FN-1, U, FI

	SFT	FRD	SKL	FRL
33015	3	1,5	4	30
33020	3	2	5	30
33030	3	3	8	30
33040A	6	4	10	50
33050A	6	5	12	50
33060	6	6	15	50



FRÄSEN PASSAR TILL
ALUMINIUM, MÄSSING, KO PPA R

Serie **117**

FN-2, B, U, FI

	SFT	FRD	SKL	FRL
117030	6	3	16	90
117060	6	6	30	130
117080	8	8	40	150
117100	10	10	50	180
117120	12	12	50	200



FRÄSEN PASSAR TILL
GRAFIT, ANDRA PLASTER

SFT - Skaftdiameter
FRD - Fräsdiameter
SKL - Skärlängd
FRL - Hela fräslängden
V - Vinkel

FN - Antal skär
U - Normalvriden / spån pressas upp ur materialet
D - Vänstervriden / fräsen pressar ner materialet
B - Radiefräs / 3D fräs
FI - Hög kvalitet

Allt inom gravyr
och skyltbranschen.

B. PIHLGREN AB

Gustaf Daléngsgatan 8, 417 05 Göteborg
Telvx. 031-50 00 50, Fax 031-23 93 45
www.bpihlgren.se, info@bpihlgren.se



Serie 91, 92, 94

FI, V, U

	SFT	FRD	SKL	V
91097	6	0,4	1	60
91099	6	0,5	1	40
91101	6	0,5	1	30
92176	6	0,1	1	90
94161	6	0,1	1	60
94163	6	0,3	1	30

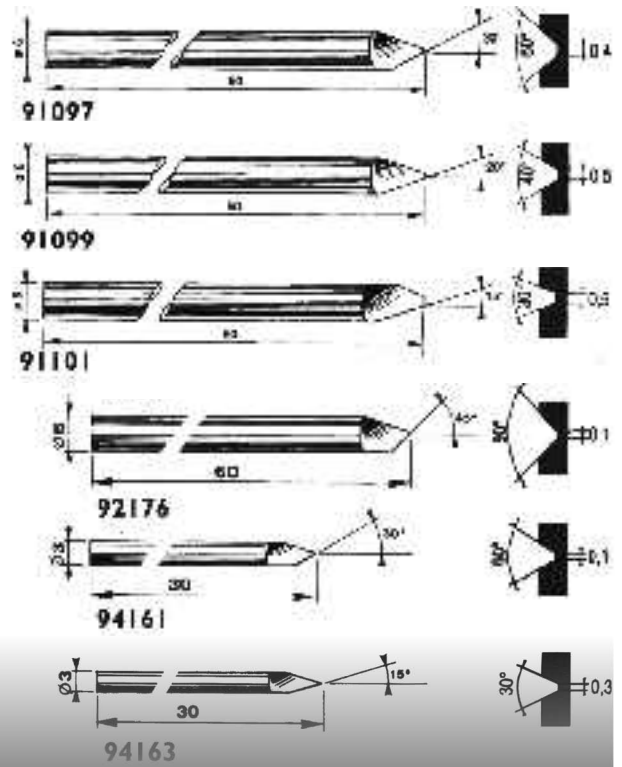

FRÄSEN PASSAR TILL
ALLA TYPER AV MATERIAL

Serie 79, 91, 93, 94

FI, U

	SFT	FRD	SKL	V
79354	2	0,5	1	10
94083	3	0,5	1	20
93072	3	1	1	20
91006	2	0,5	1	-
93071	3	0,8	1	-
93070	3	1	1	-
93069	3	1,5	1	-
93068	3	2	1	-

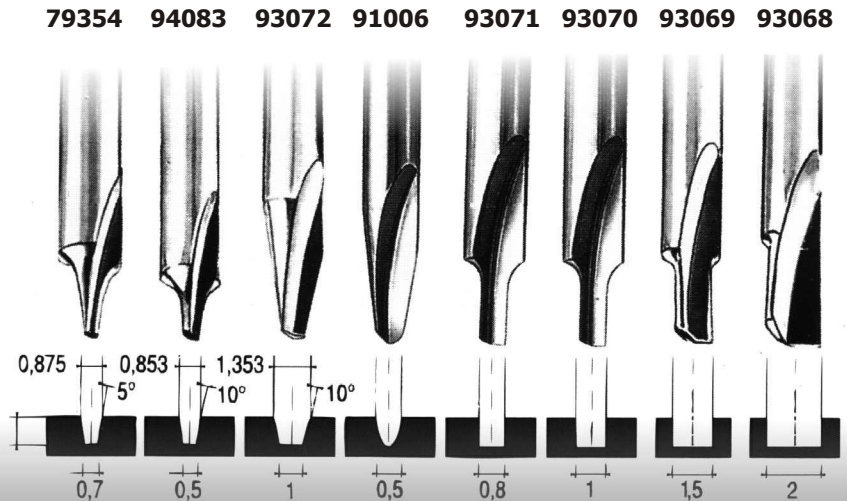

FRÄSEN PASSAR TILL
PLAST, TRÄ, KOPPAR, MÄSSING, A LUMINIUM

Allt inom gravyr
och skyltbranschen.

B. PIHLGREN AB

Gustaf Daléngsgatan 8, 417 05 Göteborg

Telef. 031-50 00 50, Fax 031-23 9345

www.bpihlgren.se, info@bpihlgren.se



SPECIALFRÄSAR

Serie **191**

FN-2, U, FI, VHM

	SFT	FRD	SKL	FRL
191.630.11	6	3	12	60
191.640.11	6	4	15	60
191.650.11	6	5	17	60
191.060.11	6	6	22	70
191.081.11	8	8	32	80
191.901.11	12	10	42	90
191.121.11	12	12	42	90



FRÄSEN PASSAR TILL
PLAST

Serie **711-911-912**

FN-2, U

	SFT	FRD	SKL	FRL
711.060.11	6	6	16	50
712.060.11	6	6	25	60
911.080.11	8	8	20	48
912.600.11	10	10	31,7	70
912.621.11	12	12	38,1	80



FRÄSEN PASSAR TILL
TRÄ, PLYWOOD, MDF

Serie **758-858-958**

FN-3, U, V

	SFT	FRD	SKL	V
758.001.11	6	1/2"	-	60°
858.001.11	6,35	1/2"	-	60°
958.001.11	8	1/2"	-	60°



FRÄSEN PASSAR TILL
TRÄ, MDF

Serie **193**

FN-2, U, FI, VHM

	SFT	FRD	SKL	FRL
193.100.11	10	10	32	80
193.120.11	12	12	42	90



FRÄSEN PASSAR TILL
PLAST

Allt inom gravyr
och skyltbranschen.

B. PIHLGREN AB

Gustaf Daléngsgatan 8, 417 05 Göteborg
Telvx. 031-50 00 50, Fax 031-23 93 45
www.bpihlgren.se, info@bpihlgren.se



Serie **312**

FN-1, U, FI

	SFT	FRD	SKL	V
312.030.025	3	0.5	1	15°
312.030.020	3	0.7	1	15°
312.030.030	3	1	1	15°



FRÄSEN PASSAR TILL
PLAST, TRÄ, ALUMINIUM, KIPPAR, MÄSSING

Serie **642**

FN-4, U

	SFT	FRD	SKL	FRL
464.1/2.010	1/2"	1"	10	40



FRÄSEN PASSAR TILL
PLANFRÄSNING

Serie **111**

FN-1, U, FI

	SFT	FRD	SKL	FRL
111.030.065	3	3	65	100
111.060.030	6	6	30	70
111.060.110	6	6	110	150



FRÄSEN PASSAR TILL
XPS, SKUM, STYRÉN

Serie **222**

FN-2, B, U, FI

	SFT	FRD	SKL	FRL
222.030.025	3	3	25	75
222.030.020	3	3	20	40
222.060.030	6	6	30	130



FRÄSEN PASSAR TILL
XPS, SKUM, STYRÉN

Allt inom gravyr
och skyltbranschen.

B. PIHLGREN AB

Gustaf Daléngsgatan 8, 417 05 Göteborg

Telvx. 031-50 00 50, Fax 031-23 93 45

www.bpihlgren.se, info@bpihlgren.se

